

# *RAW WATER FAILURE AND FUEL VACUUM ALARM INSTALLATION INSTRUCTIONS.*

## SENSOR INSTALLATION.

Sensor band will fit exhaust hose in the range of 2” to 7” diameter. For larger diameter exhaust hose, use extension kit for up to 14” diameter. Locate band down stream of water injection just after existing stainless steel hose clamps. Sensor should be mounted as shown in FIGURE TWO.

At sensor, form band around hose with fingers. Band should be square with hose and not on any angle. Tension band until snug. Use provided nylon wire ties to secure sensor cable to exhaust hose.

**Insure cable will not snag moving parts such as propeller shaft or belts. Keep cable way from hot exhaust areas before water injection point.**

## SENSOR SPECIFICATIONS:

Alarm Setpoint (fixed) 74 C (165 F)

Sensor: 10K ohms at 25 C. Max operating temperature: 149 C (300 F) , Thermal time constant 70 to 170F: 12 sec.

## BAND SENSOR MODULE

Sensor module maybe mounted in or near engine compartment/room. Ambient temperature should not exceed 150F. If engine compartment is poorly ventilated, consider mounting modules outside of engine area. Run all wires through protective boot before making any connections. Connect +12VDC terminal to switched sided of engine ignition switch. In most cases, switched power can be located at engine block. This allows alarm to be silenced by turning ignition switch OFF.

Connect sensor wires as shown on schematic. Note: sensor wires are NOT polarity sensitive. Connect output “OUT” to appropriate terminal on alarm panel. Green LED indicates module is powered. Red LED indicates alarm mode. When ignition switch is turned on, the alarm will beep and LED will flash at the alarm panel. This indicates the alarm modules are now powered and functioning properly. To test wiring connections, short across sensor input on either alarm module. The alarm will sound and appropriate LED will be ON at alarm panel. After confirming wire connections are correct, slip protective boot over module.

## VACUUM SWITCH SENSOR INSTALLATION

Switch must be located downstream of diesel fuel filter(s). Most filter housings are equipped with ¼” female pipe thread for gauge installation. Connect wires as shown on electrical schematic. Set point for alarm is fixed at 7 inHg vacuum.

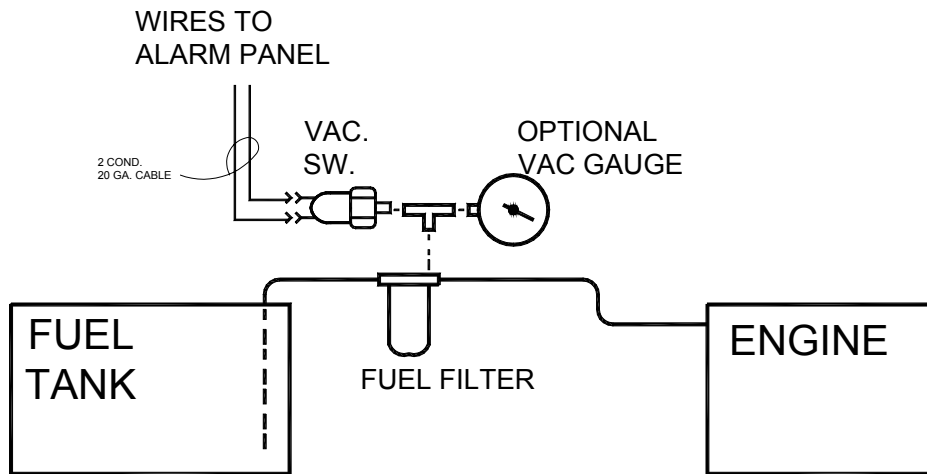

Vacuum Sensor Specifications: 42VDC max. 0.5 amps max load. Contacts N.O.  
 Closed when vacuum is above 7 inHg +/- 1

### ALARM UNIT MOUNTING AND CONNECTION.

Drill 1-7/8 TO 2" hole for mounting alarm unit. Do not attempt to remove knurled nut on face plate. Connect positive wire to any 12VDC source that is powered when engine is running. Alarm panel draws no power except in alarm mode. Connect sensor(s) as shown on electrical schematic.

*BOREL MANUFACTURING INC. • 800 824 4449 • WEBSITE: [www.borelmfg.com](http://www.borelmfg.com)  
 E-MAIL: [borelmfg@earthlink.net](mailto:borelmfg@earthlink.net)*

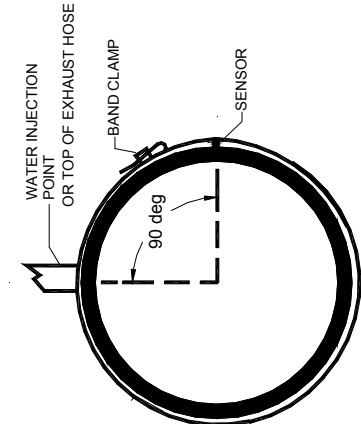

FIGURE TWO  
END VIEW OF EXHAUST HOSE

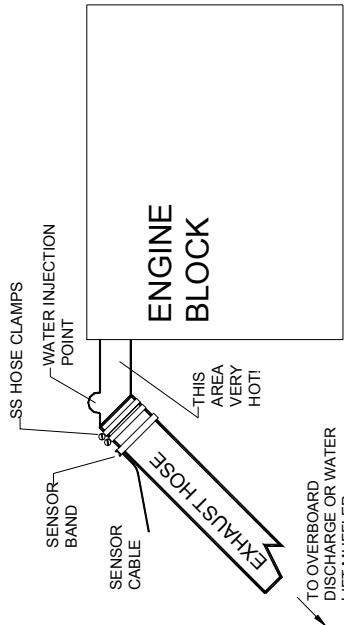
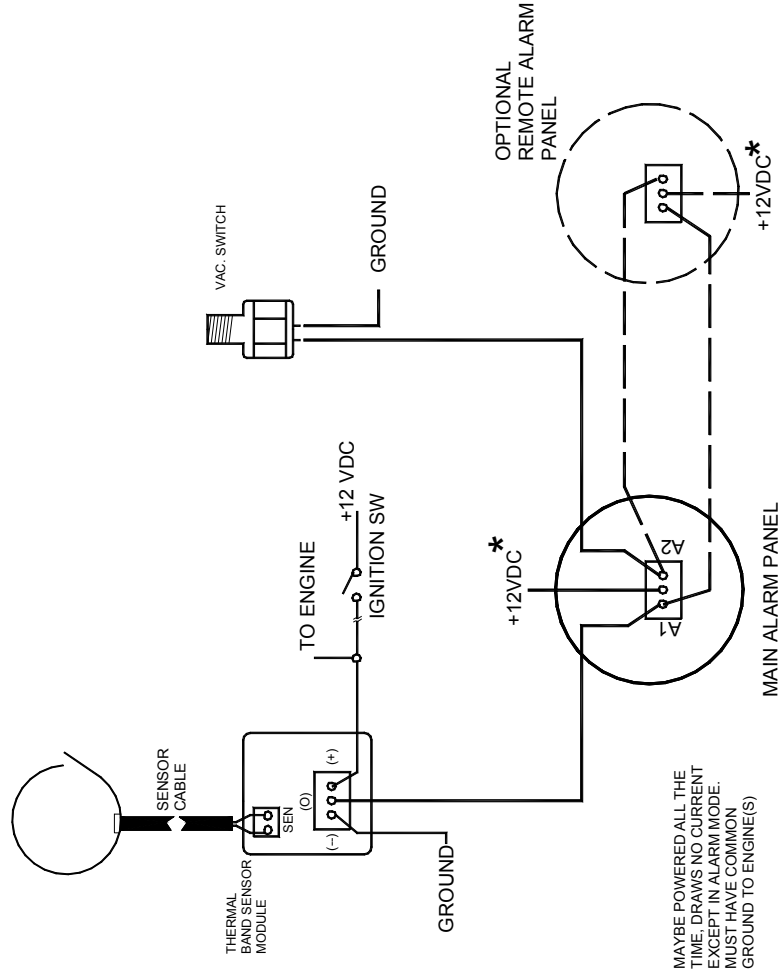

FIGURE ONE  
SENSOR INSTALLATION



\* MAYBE POWERED ALL THE TIME. DRAWS NO CURRENT EXCEPT IN ALARM MODE. MUST HAVE COMMON GROUND TO ENGINE(S)

RAW WATER AND FUEL FILTER ALARM BAND INSTALLATION AND ELE. SCHEMATIC.

BOREL MANUFACTURING INC  
SAN FRANCISCO, CA  
415 668 6907