

ENGINE RAW WATER ALARM PANEL INSTALLATION INSTRUCTIONS.

ALARM PANEL MOUNTING AND CONNECTION.

Drill 1-7/8 TO 2" hole for mounting alarm unit. Do not attempt to remove knurled nut on face plate. Run all wires through protective boot before making any wire connections. Connect horn to any 12VDC positive supply that is powered while engine is in operation. Note: alarm panel draws no current except when in alarm mode. Connect Band sensor modules to switch side of engine ignition switch. In the event of an alarm condition, turning off the ignition switch will silence the alarm. See electrical drawing that was supplied with band sensor modules.

OPTIONAL REMOTE HORN CONNECTIONS.

Remote is useful for flybridge installations. See wire diagram .

SPECIFICATIONS:

Operating voltage: 10.5 to 15V DC. Current draw 30mA (each horn)

HORN: 95 dB at 12VDC Pulsing on/off ~1Hz

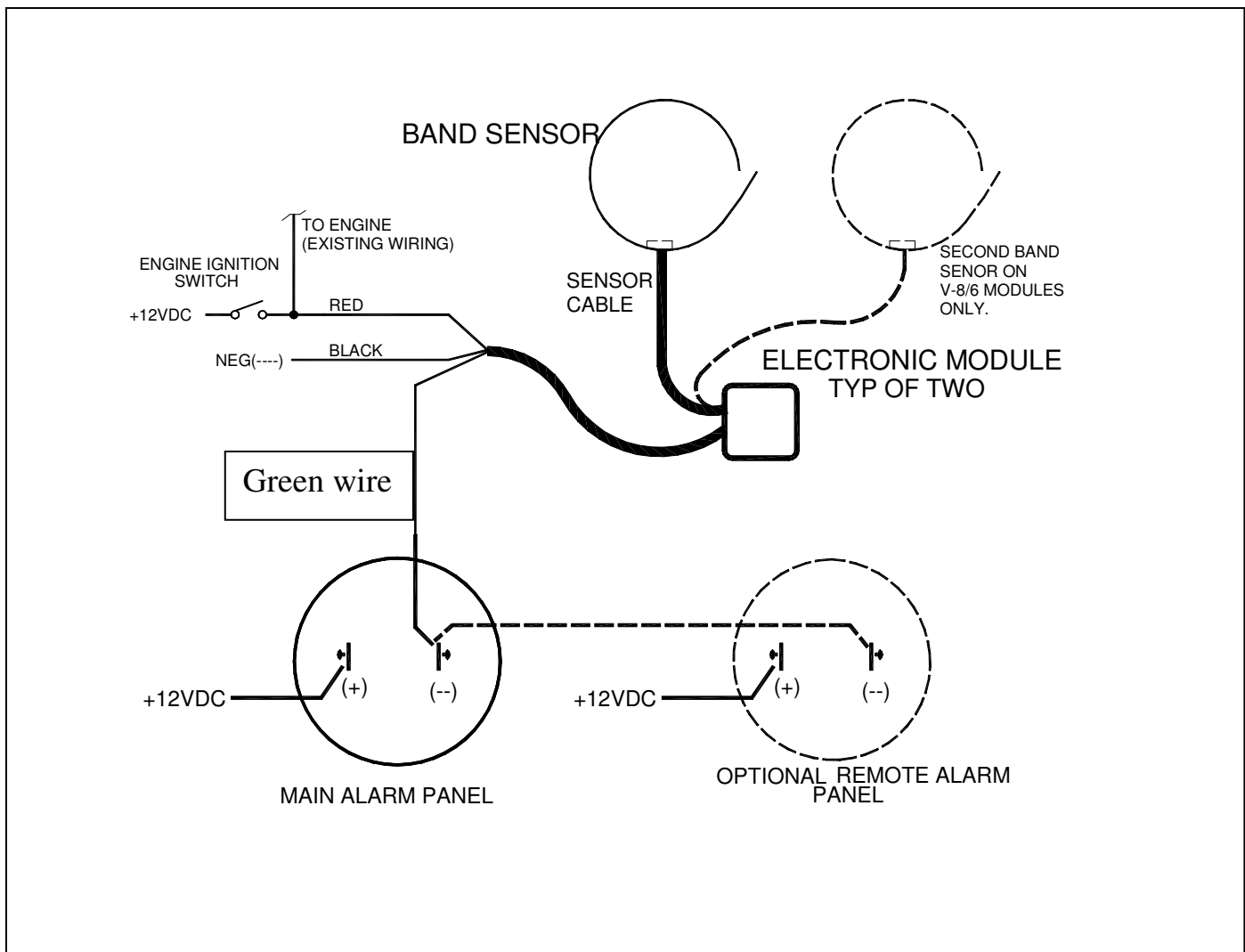

BOREL MANUFACTURING

510 864 0237 • E-MAIL: borelmfg @ earthlink.net • WEBSITE: www. borelmfg.com

RAW COOLING WATER ALARM SENSOR INSTALLATION INSTRUCTIONS.

SENSOR INSTALLATION.

Sensor band will fit exhaust hose in the range of 2" to 7" diameter. For larger diameter exhaust hose, use extension kit for up to 14" diameter. Locate band down stream of water injection just after existing stainless steel hose clamps. Sensor should be mounted as shown in FIGURE TWO.

At sensor, form band around hose with fingers. Band should be square with hose and not at any angle. Tension band until snug and lock in place. See Picture below. Make ~1" loop in sensor cable for strain relief and secure to exhaust hose using provided nylon wire tie. Alarm modules for V-8/6 engines will have two band sensors. Mount each band on each cylinder bank as described above.

Insure cable will not snag moving parts such as propeller shaft or belts. Keep cable way from hot exhaust areas before water injection point. Insure cable(s) will not chafe against sharp edges.

ALARM ELECTRONIC MODULE

Alarm electronic module contains two LED diagnostic lights. Green light indicates the unit is powered. The red light indicates an alarm condition. The alarm module should be connected to the switched side of engine ignition switch. In the event of an alarm condition, turning off the switch will silence sonic alarm. (See Electrical Connections diagram below)

TESTING

Upon turning on the ignition switch the Red LED will flash first and then Green LED will be on at the module. This indicates the alarm module is powered and functioning properly. When connected to an alarm panel, the horn will beep also.

SPECIFICATIONS:

Operating voltage: 10.5 to 15V DC

Alarm Setpoint (fixed) 75°C (167°F)

Current draw (alarm module only) : 10mA

Max Current load on control wire: 0.5A

Switching function alarm condition: Control wire goes low at temperature exceeding setpoint.

Sensor Band: Nylon coated stainless steel with 10K ohms at 25°C (77°F) thermistor.

Max operating temperature 150°C (300°F)

Thermal time constant: 12 sec from 70°F to 170°F (conduction exhaust hose to sensor)

*BOREL MANUFACTURING INC. • 510 864 0237 • WEBSITE: www.borelmfg.com
E-MAIL: borelmfg@earthlink.net*

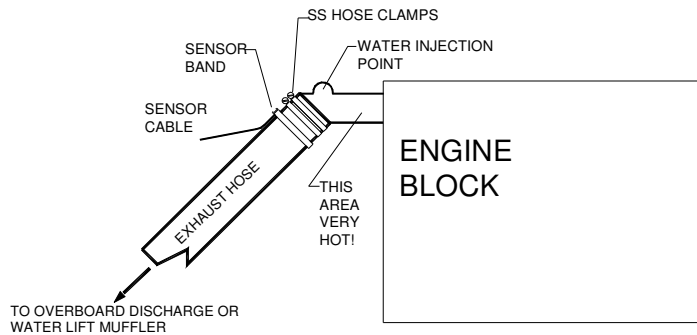

FIGURE ONE
SENSOR INSTALLATION

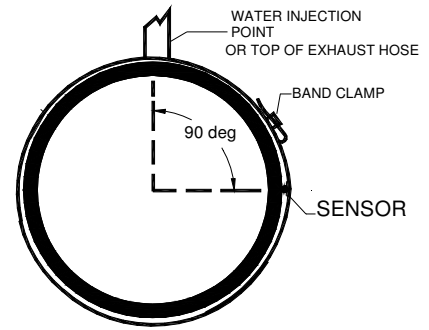
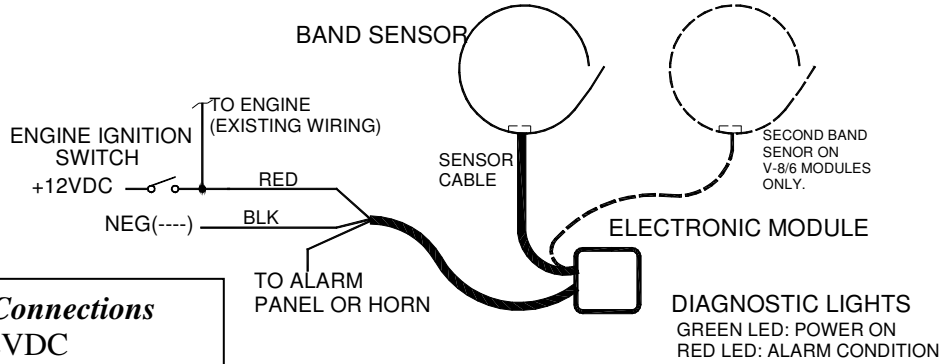
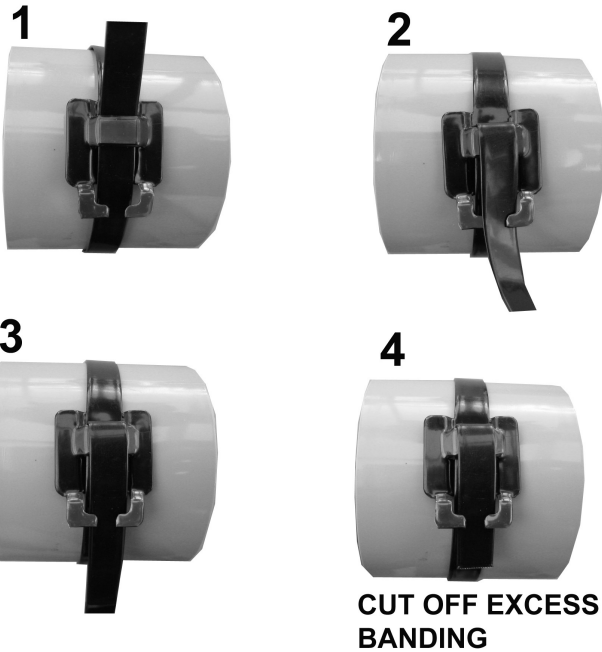

FIGURE TWO
END VIEW OF EXHAUST HOSE



ELECTRICAL CONNECTIONS

Wire Connections
 RED: +12VDC
 BLACK: NEG (---)
 GREEN: Alarm Output



**LOCKING BAND CLAMP
INSTALLATION**

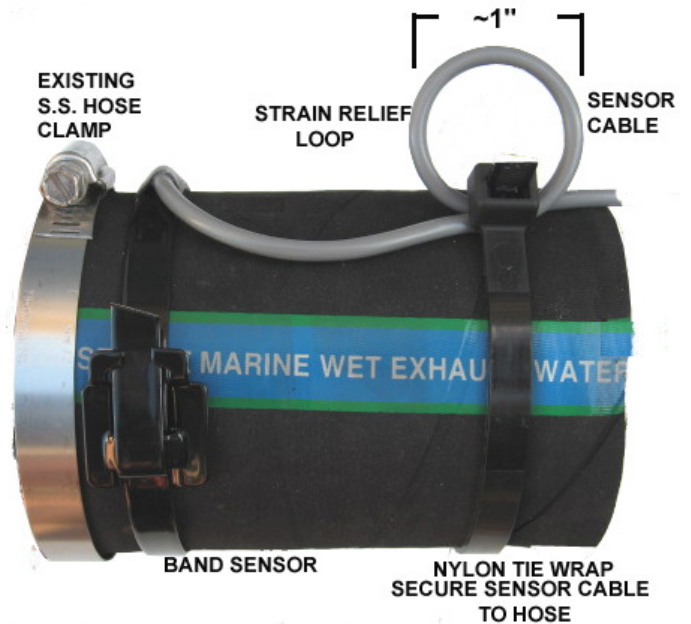

TYPICAL INSTALLATION
 See "FIG TWO, End view exhaust hose" for
 Sensor location